

**Perfecting the process.
Discovering flexibility.
Measuring excellence.**

Rotary Encoder Product Overview



Your automation, our passion.

PEPPERL+FUCHS



Contents

Industries	4
Technology and Measuring Methods	5
Industry-Standard Rotary Encoders	10
Incremental Rotary Encoders	11
Absolute Rotary Encoders	16
Bearing-Free Rotary Encoders	22
Heavy-Duty Rotary Encoders	24
Rotary Encoders for Offshore Applications	28
Rotary Encoders for Hazardous Areas	32
Rotary Encoders for Safety Applications and Safety Controller	38
Cable Pulls and Cable Pull Rotary Encoders	42
Accessories and Other Components	48

Whatever the Industry, Complex Applications Require Technology that Works Reliably under All Circumstances

Virtually every industry operates in a global market environment. Ever increasing demands on machine performance call for solutions that combine reliability with high performance. These solutions include rotary encoders that best fit the design environment of a machine and offer just the features you need. Using the latest technology, Pepperl+Fuchs offers rotary encoders that are robust and compact in design.

Tailor-Made Solutions

At Pepperl+Fuchs, the focus is always on the application. Working in close cooperation with our customers, we provide customized solutions through a streamlined development process. Our ability to go beyond the standard product portfolio to meet your needs ensures that the result is optimally tailored to the application. In this way, our solutions set new standards, meet the highest demands, and ensure excellent quality assurance.

Works Reliably in Any Environment

Rotary encoders convert angular position used to determine position, speed, and acceleration. These rotary encoders, which are a key component of modern automation technology, control rotating and linear movements. Pepperl+Fuchs offers a comprehensive range of different rotary encoders that open up a wide range of applications. Pepperl+Fuchs encoders can be applied to many applications in many different industries.

Industries:

- Machine and plant engineering
- Mobile equipment
- Renewable energy
- Material handling
- Print and paper industry
- Packaging industry
- Automotive industry
- Oil and gas, chemical industry
- Offshore and shipbuilding
- Doors, gates, and elevators

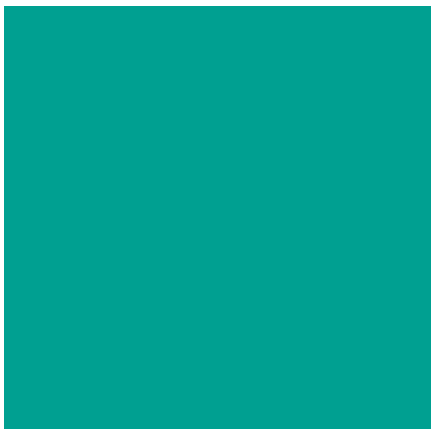
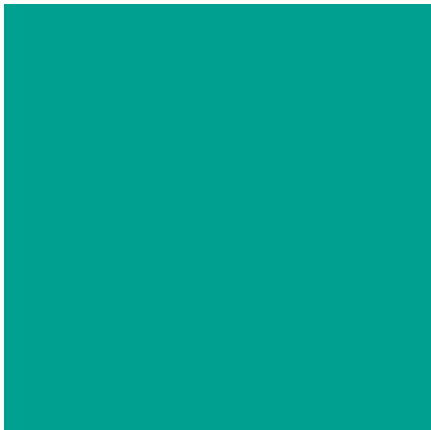
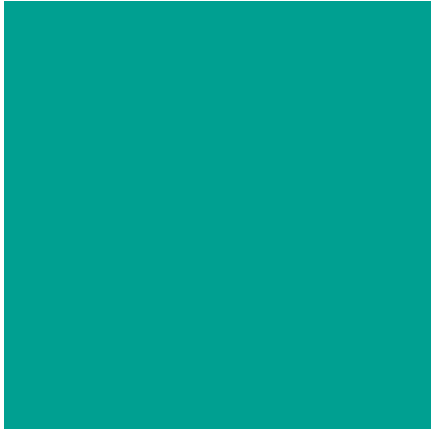

Incremental and Absolute Rotary Encoders for Optimal Performance

Each rotary encoder application has its own unique requirements. When looking for the best application solution, there are several types of encoders that you can choose from. These types are characterized by different measuring methods, signal outputs, and mounting preferences.

Incremental Rotary Encoders

Incremental rotary encoders are used to detect the speed and position of a shaft. A precisely defined number of pulses, up to 50,000, are delivered for each revolution of the shaft. These pulses are output by the rotary encoder and allow accurate determination of the rotational speed. If the pulses are referenced to a certain point, like the change in angle caused by the rotation or the distance traveled, you can determine your position. Two-channel rotary encoders deliver 90° phase-shifted output signals. These signals allow you to detect the direction of rotation in order to control the bidirectional positioning of a shaft. Three-channel rotary encoders deliver an additional zero signal for each revolution.

Absolute Rotary Encoders

Absolute rotary encoders deliver a clearly defined numerical value for each position of the shaft. Because the connected controller does not have to make complex calculations, you do not need costly input components. The absolute position value is available at any time. No time-consuming machine homing cycles are required when the machine is switched on or after a power failure.

Single Turn and Multiturn

With absolute rotary encoders, there is a difference between single turn and multiturn versions. For single turn absolute rotary encoders, one complete revolution of the shaft is divided into a maximum of 65,536 measuring steps (16 bit). After each full revolution, the coding starts at its original start value. For single turn encoders, the electronics are not able to detect the number of revolutions. In contrast, multiturn absolute rotary encoders can detect the number of revolutions. When communicating position, multiturn encoders provide a total resolution up to 32 bit depending on the technology. This total bit count includes single turn resolution and number of turns.

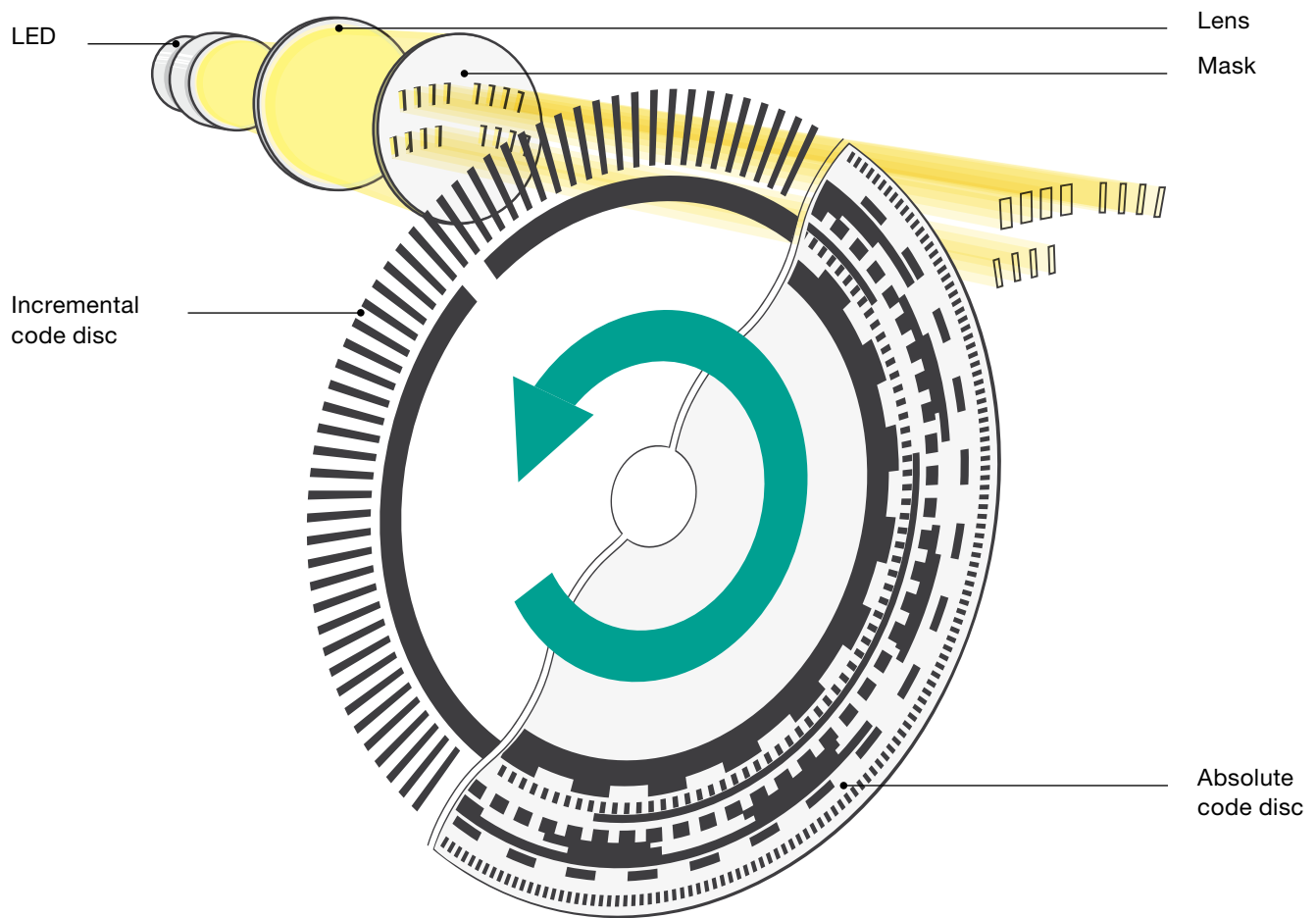

Photoelectric Detection: Recognize and Detect Movements

An internal rotating code disc is scanned in parallel using an optical element. Rotation of the code disc generates a periodic modulation of the light beam between the LED and sensor. This modulation is converted into a sinusoidal electrical signal by the rotary encoder. An incremental rotary encoder code disc has radial slits. The number of slits determines the resolution. In optical absolute rotary encoders, a rotary disk with a Gray code delivers a unique pattern for each angular position.

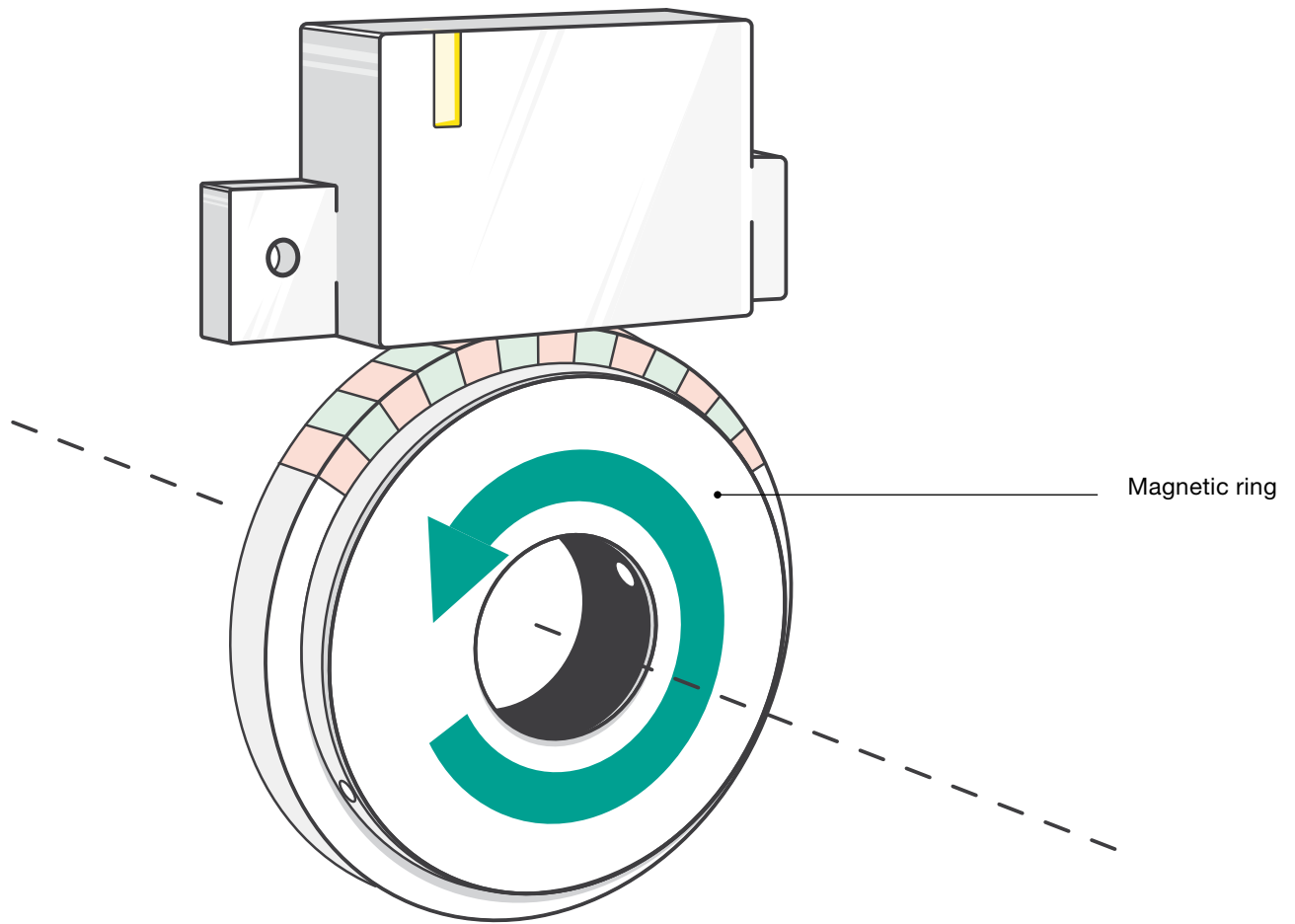

Magnetic Detection: Robust Functionality in a Harsh Environment

Reliable performance is the basic requirement for any modern machine. Magnetic rotary encoders offer extremely robust sensing properties based on the magnetic detection principle. They also allow maximum precision and reach new levels of efficiency, flexibility, and performance.

Magnetic Detection with AMR and GMR Effect

The anisotropic magnetoresistance effect (AMR) is based on the scattering in ferromagnetic metals dependent on the spatial direction. It occurs in all materials that have independent magnetization properties. AMR sensors respond to changes in the direction of this magnetic field.

The giant magnetoresistance effect (GMR) is similar, although the change in resistance of the electrical conductor is in excess of 50 %. This effect occurs in layered systems of ferromagnetic metals (FM) separated from one another by thin, nonmagnetic metals (N).

Pepperl+Fuchs offers incremental rotary encoders that work on the basis of these two effects and allow highly precise detection of the position and rotational speed of a shaft. Rotary encoders from this series are characterized by highly compact housings and high environmental protection.

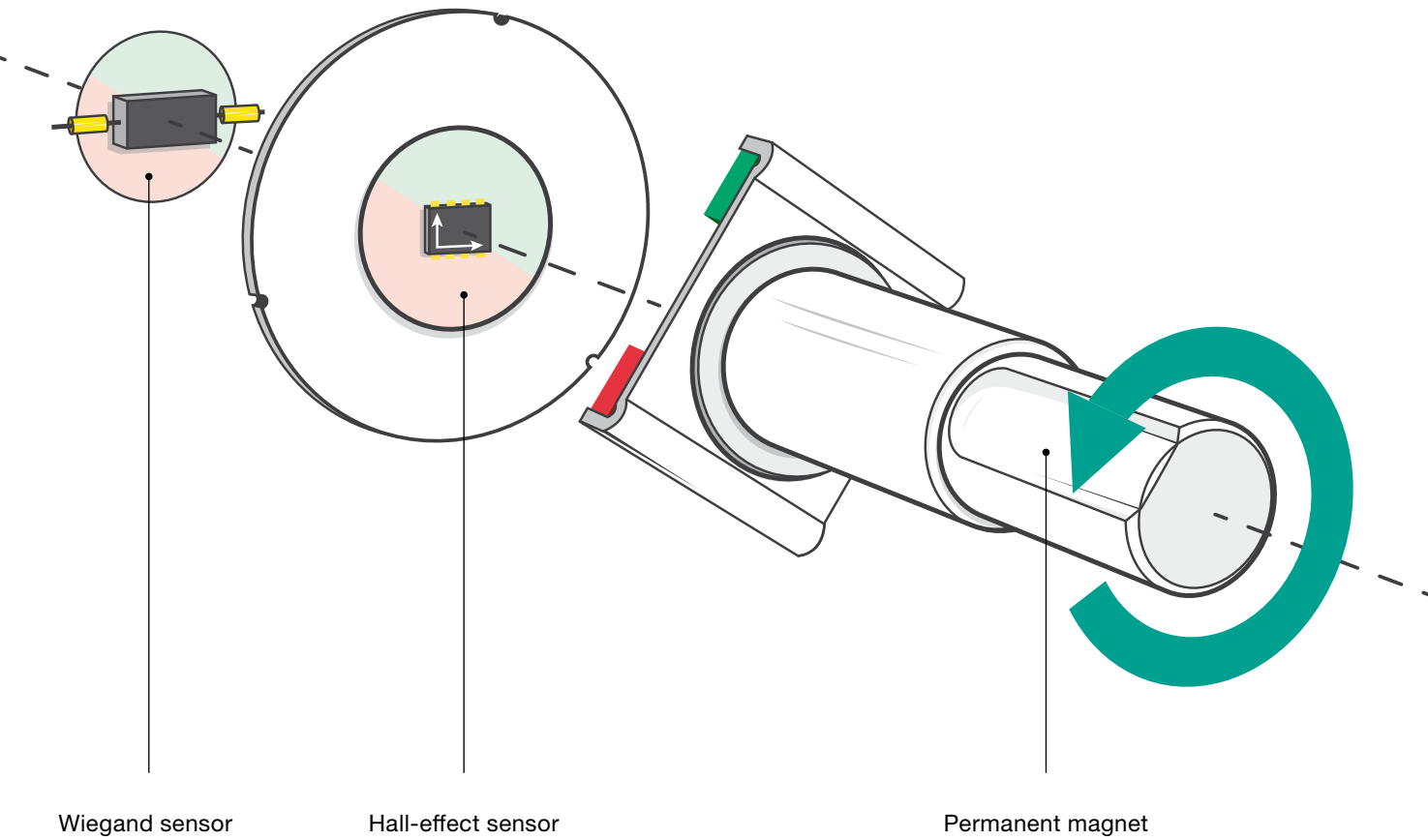

Wiegand sensor

Hall-effect sensor

Permanent magnet

Hall-Effect and Wiegand Sensors

Pepperl+Fuchs uses a twin-axis Hall-effect sensor based on the magnetic detection principle in its absolute rotary encoders. This type of sensor uses a rotating magnetic field to generate sine and cosine pulses. A digital signal is generated from these pulses via an internal processor. This signal is identical to the signal from an absolute rotary encoder with optical detection.

Magnetic absolute rotary encoders are also available in a multiturn version. These are equipped with an additional Wiegand sensor. A key element of this is a magnetic field that rotates continuously around the sensor and causes a change in the direction of the magnetic field twice per revolution. The resulting induction voltage supplies power to the electronics. This power is interpreted by the sensor and converted into a digital signal. Due to the self-supply via the permanent magnetic field, the sensor can track shaft turn even when power is removed and is therefore completely immune to power failures. Absolute data security is guaranteed and all position values are available immediately after the machine is powered back up.

Incremental Rotary Encoders: Precise Position Detection for Reliable Automation

Incremental rotary encoders form the bridge between mechanics and electronics. They detect rotation angles and output a signal pulse so the speed or position of the rotating part can be determined. The task is to deliver exactly those signals that permit automatic control of rotation sequences. Pepperl+Fuchs provides a full range of rotary encoders to cover a wide range of applications for a variety of industries.

Built-In Reliability

Maximum speed, process reliability, and machine availability are customer priorities. Rotary encoders from Pepperl+Fuchs are the perfect way to meet these priorities. They deliver accurate measurement results for reliable processes. Their robust technology prevents costly downtime. With high accuracy and resolutions up to 50,000 pulses, each incremental rotary encoder delivers precision tailored exactly to your requirements.

Compatibility with Industry Standards

The trend in modern mechanical engineering is moving toward compact designs. The rotary encoders from Pepperl+Fuchs are embracing this trend. A diameter of only 40 mm makes them the best solution for tight installation locations. Their extremely robust housings allow reliable detection even under harsh operating conditions. Their seamless integration into the existing system environment is consistent with recognized industry standards. Standard connection, mounting, and interfaces are available.

Typical Areas of Application

- Machine and plant engineering
- Doors, gates, and elevators
- Print and paper industry
- Material handling
- Medical technology
- Packaging industry
- Renewable energy
- Food industry
- Pharmaceutical industry
- Chemical industry
- Mobile equipment

Maximum Flexibility with Minimal Space Requirements

Impressive features of this incremental rotary encoder include its compact dimensions and flexible cable routing. These features make this encoder the ideal solution for applications in small confined areas. This encoder is available as a complete solution for elevators, and has established itself in rotation speed monitoring applications in medical technology.



Performance in a Compact Format

With a housing diameter of just 40 mm, this incremental rotary encoder is ideal for shaft positioning in elevators and is specially tailored as a complete solution for elevator construction. The encoder is available with different types of shafts to fit a variety of applications. Electrical integration makes this encoder incredibly easy to use due to its RS-422 functionality at 5 V operation.

Technical Information	
Design	Ø 40 mm
Shaft type	Solid, recessed hollow, and hollow shaft
Shaft dimension	Ø 6 mm, Ø 8 mm, 1/8", 1/4", 3/16", and 5/16"
Flange type	Clamping flange, hollow shaft flange with torque rest
Max. rotational speed	6,000 rpm
Degree of protection	IP54
Max. shaft load	Axial: 20 N, radial: 30 N
Connection type	Cable
Connection output	Tangential and radial
Electrical interface	Push-pull or RS-422, depending on the supply voltage
Resolution	Up to 1,024 pulses
Order code	TVI40, TSI40, THI40

Highlights

- Compact design for use in confined spaces
- Flexible cable routing and mounting with tangential cable outlet
- Flexible electrical integration through utilization of RS-422 functionality
- Complete solution for elevator construction

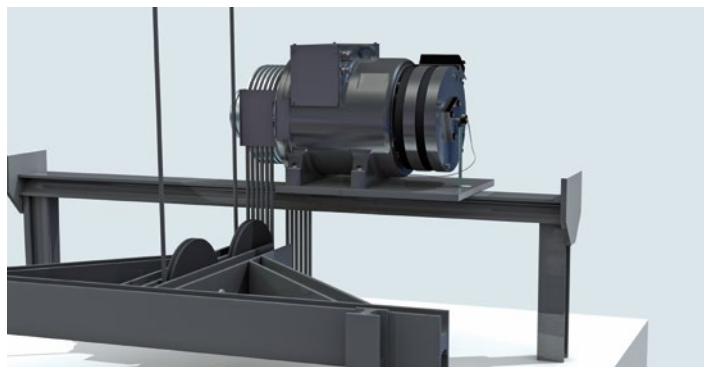

In shaft positioning applications, the compact rotary encoder monitors the motor speed and guarantees safe transport.

Broad Portfolio with Unmatched Precision

When maximum signal quality and precision are required, the ENI58IL incremental rotary encoder is the product of choice. The integrated BlueBeam Technology uses a blue LED to provide improved resolution and reduced jitter, delivering accurate, reliable measurements.



Impressive Features

BlueBeam Technology in combination with a precisely calibrated code disc allows maximum signal quality and precision, even at high rotational speeds. Our broad portfolio makes these benefits available in almost any application: You can always find the right configuration, with a large number of shaft, flange, and connection options for worldwide use.

The heavy-duty design guarantees maximum system and process reliability. In addition to extreme mechanical vibration and shock resistance, special EMC circuit protection provides high interference immunity. Interlocked bearings withstand high loads and protect the ball bearing. With these features, the ENI58IL is not just the new industry standard – but also a perfect fit for high-performance applications.

Technical Information

Housing design	Ø 58 mm
Mechanical variants	Solid shaft: clamping, servo and square flange; recessed hollow and hollow shaft
Max. rotational speed	12,000 rpm
Degree of protection	IP65, IP67
Shock/vibration resistance	300 g/30 g
Connection type	Cable, M12 plug, M23 plug, MIL7 plug, MIL10 plug
Connection output	Axial and radial
Electrical interface	Push-pull or RS-422, universal current driver (output level dependent on output voltage)
Resolution	Up to 5,000 pulses, higher resolution on request
Order code	ENI58IL-S, ENI58IL-S**Q, ENI58IL-R, ENI58IL-H

Highlights

- BlueBeam Technology: unmatched precision even at rotational speeds up to 12,000 rpm
- A complete portfolio of shaft, flange, and connection options offers the optimal solution for a wide range of applications
- Heavy-duty design with interlocked bearings withstands high bearing loads and ensures long service life
- High shock and vibration resistance paired with EMC circuit protection for maximum system and process reliability

Stainless Steel for Use with Foods

This encoder meets the highest standards for use in the pharmaceutical, chemical, and food industry. Its stainless steel housing is hygienically designed to comply with certified microbiological safety in accordance with EHEDG. It offers maximum resistance to aggressive chemical substances in accordance with ECOLAB.



Durable and Extremely Reliable

The food, chemical, and pharmaceutical industries are known for their high requirements for hygiene, easy cleaning, and resistance to aggressive substances. The stainless steel housing of this encoder meets these very requirements. This encoder is resistant to thermal shocks. It can be easily cleaned with a high-pressure washdown. It supports high machine availability and seamless process flows.

Technical Information	
Design	Ø 58 mm
Shaft type	Solid shaft
Shaft dimension	Ø 10 mm
Flange type	Clamping flange
Max. rotational speed	3,600 rpm
Degree of protection	IP67 and IP69K
Max. shaft load	Axial: 100 N, radial: 100 N
Connection type	Cable
Connection output	Axial and radial
Electrical interface	Push-pull and RS-422
Resolution	Up to 25,000 pulses
Order code	RVI58L

Highlights

- Materials extremely resistant to aggressive chemical detergents and disinfectants
- Design allows easy cleaning of encoders and therefore microbiological safety
- Impermeability in applications involving a high-pressure cleaner, even when exposed to repeated thermal shocks
- Higher machine availability due to short cleaning times and long service life
- Can be used for longer cable lengths via RS-422 electrical interface with 10 V–30 V supply voltage

Dynamic Machine Operation Meets Reliability

This encoder offers exactly the right features for trouble-free and reliable processes where the environment is exposed to high electromagnetic loads. Its special design for accommodating shafts allows use in applications with highly dynamic loads, while at the same time permitting long runtimes. The low installation depth and the ability to accommodate large drive shafts is a distinctive advantage for applications in drive and elevator technology.



Special Housing Design for Secure Process Flows

This encoder can accommodate both very small and large drive shafts from 16 mm to 45 mm.

A winning feature is its relatively small external diameter, which allows mounting in confined spaces.

A hollow shaft with flat areas on both sides allows positive, backlash-free connection and prevents the shaft from slipping and twisting. It is ideal for dynamic applications. It has a high degree of immunity that prevents failure even in environments exposed to high electromagnetic loads.

Technical Information

Design	Ø 90 mm
Shaft type	Hollow shaft and shaft with flat areas on both sides
Shaft dimension	Hollow shaft: Ø 16 mm–Ø 45 mm (12 mm with reducing bush)
Flange type	Hollow shaft flange with torque rest
Max. rotational speed	3,500 rpm
Degree of protection	IP54 and IP65
Connection type	Connector plugs and cables
Connection output	Radial
Electrical interface	Push-pull and RS-422 and sine/cosine
Resolution	Up to 50,000 pulses
Order code	RHI90, RHS90, THI90

Highlights

- High process reliability even in environments subject to EMC interference
- Use in highly dynamic applications with backlash-free connection of the shaft
- Accommodation of large shaft diameters
- Fast and easy installation with threaded pins (60° set screws)
- Compact design for use in confined spaces



Absolute Rotary Encoders: Precise Information for Complex Control Tasks

Absolute rotary encoders are ideal in any application where precise and delicate control of movement is required. These encoders are at the heart of this action. They provide excellent resolution. They stand out for their robust technologies that deliver reliable information even in demanding operating conditions. Absolute rotary encoders are available with both magnetic and optoelectronic scanning and are suitable for a wide range of applications.

Magnetic, Robust, Reliable

Magnetic rotary encoders from Pepperl+Fuchs set new standards. Based on a proven design principle, they are accurate to $<0.1^\circ$. Using a Wiegand sensor allows for a more compact design and eliminates the need for gears. Magnetic encoders are also more reliable due to their resistance to shock and vibrations, and their ability to withstand harsh environments of dirt, dust, and extreme temperatures from -40°C to 85°C .

Optically Perfect and Absolutely Precise

Optical absolute rotary encoders from Pepperl+Fuchs represent absolute quality. They achieve the greatest accuracies of up to 0.01° . They are the perfect choice for all applications with the highest requirements for dynamic machine operations and accuracy. Typical areas of application include modern CNC machines, as well as many other applications where maximum precision is the benchmark.

Typical Areas of Application

- Machine and plant engineering
- Material handling
- Doors, gates, and elevators
- Medical technology
- Mobile equipment
- Print and paper industry
- Packaging industry
- Automotive industry
- Renewable energy

Totally Robust and Especially Compact

This compact absolute rotary encoder is perfect for any application that requires a space-saving solution and reliable continuous operation. Its mechanical concept is based on maximum robustness that provides noncontact operation, even when exposed to constant vibration.



Easy Commissioning

A key feature of this encoder is its housing diameter of just 36 mm. The analog output option encoder allows for easy programming by using the two Teach-in push buttons. It offers an accuracy of $< 1^\circ$ and a total resolution of up to 25 bit. Its robust housing design opens up numerous application fields such as machine engineering, plant engineering, and material handling.

Technical Information		
Design	Ø 36 mm	
Shaft type	Solid and recessed hollow shaft	
Shaft dimension	Ø 6 mm	
Flange type	Servo flange and hollow shaft flange with torque rest	
Max. rotational speed	12,000 rpm	
Degree of protection	IP50, IP54, and IP65	
Max. shaft load	Axial: 20 N, radial: 40 N	
Connection type	Connector plugs and cables	
Connection output	Axial and radial	
Electrical interface/order code	SSI	AVS36M, AVM36M, ASS36M, ASM36M
	J1939	JVS42M, JVM42M, JSS36M, JSM36M
	CANopen	CVS36M, CVM36M, CSS36M, CSM36M
	Analog	IVS36M, IVM36M, UVS36M, UVM36M, USS36M, USM36M
Max. bit count	Single turn: 4,096 (12 bit), multiturn: 8,192 (13 bit)	

Highlights

- Compact design for confined spaces
- Easy commissioning with Teach-in push buttons (analog interface)
- Noncontact technology allows for long service life
- Robust design opens up a wide range of possible applications

Precision Guaranteed

This absolute rotary encoder is not only small and thus ideal for installation in confined spaces, it also provides highly precise measurements which are not disrupted by constant shock and vibrations. This makes this encoder the right solution for highly dynamic applications such as industrial robots.



Accuracy with No Ifs, Ands, or Buts

Total resolution of up to 16 bit and an accuracy of $<0.1^\circ$ make this encoder the ideal solution for dynamic applications where precise positioning is important. Universally robust technology makes it completely insensitive to shocks and vibrations. This sensor is perfect for robotics as well as for rotation speed monitoring in drive technology.

Technical Information	
Design	Ø 36 mm
Shaft type	Solid and recessed hollow shaft
Shaft dimension	Ø 6 mm
Flange type	Servo flange and hollow shaft flange with torque rest
Max. rotational speed	12,000 rpm
Degree of protection	IP54, IP64, and IP65
Max. shaft load	Axial: 20 N, radial: 40 N
Connection type	Connector plugs and cables
Connection output	Axial and radial
Electrical interface/order code	SSI ENA36IL
Max. bit count	Single turn: 65,536 (16 bit), multiturn: 65,536 (16 bit)

Highlights

- First magnetic rotary encoder technology with Hall-effect sensor for highly dynamic processes
- Very high resolution and absolute accuracy of $<0.1^\circ$ for high-precision applications
- Compact design for confined spaces
- Noncontact technology facilitates a long service life and reduces maintenance demands

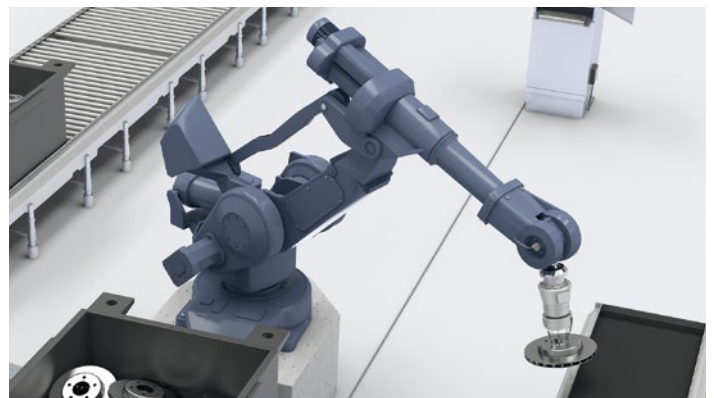

The small magnetic rotary encoder controls the rotation of the robot arm and ensures reliability in the production process.

An All-Round Solution for Versatile Use

With an accuracy of $<0.1^\circ$, this absolute rotary encoder has opened up a wide variety of applications. In the print and paper industry, this encoder controls the positioning of the rollers. When used with handling machines, it monitors rotational speed and position. Its robust bearing design even allows it to be used in extremely harsh environments, such as in wind turbines.



Robust Performance to Industry Standards

A housing diameter of 58 mm makes this encoder ideal for use in a number of industrial applications. It is available with both a solid shaft and recessed hollow shaft, ensuring the best adaptation to a wide variety of applications. A total of 32 bit for number of turns and resolution combined with its high resistance to shocks and vibrations goes above and beyond the industry standard.

Technical Information	
Design	Ø 58 mm
Shaft type	Solid and recessed hollow shaft
Shaft dimension	Solid shaft: Ø 6 mm–Ø 10 mm Recessed hollow shaft: Ø 6 mm–Ø 15 mm
Flange type	Servo flange; hollow shaft flange with torque rest
Max. rotational speed	12,000 rpm
Degree of protection	IP65 and IP67
Max. shaft load	Axial: 40 N, radial: 110 N
Connection type	Connector plugs and cables
Connection output	Axial and radial
Electrical interface/order code	SSI, PROFIBUS, PROFINET, EtherCat ENA58IL
Max. bit count	Single turn: 65,536 (16 bit), multiturn: 65,536 (16 bit)

Highlights

- First magnetic rotary encoder technology with Hall-effect sensor for highly dynamic processes
- Very high resolution and absolute accuracy of $<0.1^\circ$ for high-precision applications
- Compact design in all standard interfaces for flexible use
- Noncontact technology allows a long service life
- The corrosion- and saltwater-resistant design opens up a wide variety of applications, even in extreme conditions



In a flying saw, the encoder takes control of the material advancement or it is used in linear or rotary axis of the tool.

Specializing in Maximum Precision

This encoder is the perfect solution for applications requiring maximum precision. Its optical detection principle achieves accuracies to $<0.01^\circ$ and represents the absolute top of the line. For use in applications with CNC machining centers with the highest requirements for dynamic machine operations and accuracy.



Precision Meets Versatility

Impressive key features of this encoder include a total of 30 bit for number of turns and resolution, a wide range of flange, shaft, and connection variants, and all common fieldbus interfaces. It can be flexibly integrated into any system environment. A removable bus cover allows easy handling during installation and maintenance in the field. A high degree of flexibility and a comprehensive range of accessories allow specific adaptation to a wide range of applications.

Highlights

- Very high resolution and accuracy of $<0.01^\circ$ for precise and dynamic applications
- Flexible system integration via standard fieldbus interfaces
- Simplified installation and maintenance via removable bus cover
- The corrosion- and saltwater-resistant design opens up a wide variety of applications, even in extreme conditions

Technical Information

Design	Ø 58 mm	
Shaft type	Solid, recessed hollow, and hollow shaft	
Shaft dimension	Solid shaft: Ø 6 mm–Ø 10 mm, Recessed hollow shaft: Ø 6 mm–Ø 15 mm	
Flange type	Servo flange; hollow shaft flange with torque rest	
Max. rotational speed	12,000 rpm	
Degree of protection	IP64, IP65, and IP66	
Max. shaft load	Axial: 40 N, radial: 110 N	
Connection type	Connector plugs and cables	
Connection output	Axial and radial	
Electrical interface/order code	SSI, RS-422 SSI+incremental track, push-pull SSI+incremental track	AVS58, AVM58, ASS58, ASM58, AHS58, AHM58
	CANopen	CVS58, CVM58, CSS58, CSM58
	PROFIBUS	PVS58, PVM58, PSS58, PSM58
	EtherNet/IP, EtherNet POWERLINK, PROFINET, TCP/IP, EtherCat	EVS58, EVM58, ESS58, ESM58
	DeviceNet	DVS58, DVM58, DSS58, DSM58
	AS-Interface	BVS58, BVM58, BSS58, BSM58
	Parallel	FVS58, FVM58, FSS58, FSM58
Max. bit count	Single turn: 65,536 (16 bit), multiturn: 16,384 (14 bit)	

Bearing-Free Rotary Encoders: Reliable Sensors for Noncontact Continuous Operation

Bearing-free rotary encoders are known for their compact design and combine a robust measuring system with intelligent assistance functions. Noncontact detection leads to a much longer sensor life and provides the best conditions for reliable continuous operation, even in dusty or dirty environments.



Typical Applications

- Machine and plant engineering
- Mobile equipment
- Material handling
- Print and paper industry
- Renewable energy



MNI40 with a magnetic wheel for rotation speed monitoring on the motor of a machine tool.

Noncontact

Robust technology, reliable continuous operation, and easy installation are the main selling points of the technology used by this incremental rotary encoder. This encoder is available in versions with a magnetic ring or magnetic wheel. With a noncontact connection between the sensor and the magnetic wheel, the rotary encoder does not need ball bearings. This noncontact connection guarantees a long service life, even at high rotational speeds up to 30,000 rpm. You can also accommodate significantly larger hollow shaft diameters than is possible with conventional rotary encoder solutions.

Minimal Installation Costs

The bearing-free rotary encoder stands out for its simple mounting, which significantly reduces installation costs. Intelligent assistance functions support quick and easy commissioning. Critical system information can be read from a two-color LED status indicator.

Technical Information	
Shaft type	Hollow shaft
Shaft dimension	Up to Ø 30 mm, larger diameters on request
Max. rotational speed	30,000 rpm
Degree of protection	IP67, IP68, and IP69K
Connection type	Cable
Connection output	Radial
Electrical interface	Push-pull and RS-422
Resolution	Up to 7,200 pulses
Order code	MNI20, MNI40

Highlights

- Assistance functions and LED indicator for simplified installation and testing
- Quality assurance provided by full self-diagnostics, including for the magnetic wheel
- Resistant to dirt and thermal and mechanical shocks
- Efficient solution with long service life at high rotational speed and temperature
- Reliable function even for shaft movement of up to 1 mm



Heavy-Duty Rotary Encoders: Robust Encoders for the Toughest Conditions

Some applications have extreme requirements. For example, outdoor processing plants that are constantly exposed to changing weather conditions, or construction machinery that is operated in dusty, dirty environments. Heavy-duty rotary encoders from Pepperl+Fuchs combine precise functionality with long-lasting durability.

Proven Technology in Sturdy Packaging

These rotary encoders are specially designed for heavy-duty use. Immune to electromagnetic interference, they can cope with constant vibration and high impact. These encoders are unaffected by heat, cold, or dirt. They deliver precise measurement results at all times. Their robust and compact design sets new standards and opens up new applications.

Typical Areas of Application

- Machine and plant engineering
- Mobile equipment
- Print and paper industry
- Offshore and shipbuilding
- Sawmills

A Rotary Encoder with Resilience

This rotary encoder guarantees reliable measurement results in harsh environments. One field of application where it is used is in speed feedback for large asynchronous motors. Its exceptionally robust design withstands extreme environmental conditions, such as heat, cold, dirt, constant vibrations, severe shocks, and electromagnetic interference.



Completely Flexible and Reliable

This rotary encoder offers comprehensive protection against shaft currents. It is insensitive to electromagnetic emissions. Its extreme resistance to vibrations and shocks makes this a highly resilient component that guarantees high process reliability and minimal failure risk. Its 4× 90° swiveling junction box simplifies handling and allows cables to be installed quickly and flexibly in the field.

Technical Information

Design	Ø 110 mm
Shaft type	Recessed hollow shaft, hollow shaft, and tapered recessed hollow shaft
Shaft dimension	Hollow shaft: up to Ø 28 mm Recessed hollow shaft: up to Ø 20 mm Tapered shaft: Ø 17 mm
Flange type	Hollow shaft flange with torque rest (support plate and articulated arm)
Max. rotational speed	3,000 rpm
Degree of protection	IP66/IP67 and IP69K
Max. shaft load	Axial: 300 N, radial: 400 N
Connection type	Junction box with cable duct, connector plugs, and cables
Connection output	Tangential
Electrical interface	Push-pull, RS-422
Resolution	Up to 2,500 pulses
Order code	ENI11HD

Highlights

- High reliability via protection against shaft currents
- Extremely easy installation and maintenance due to a 4× 90° swiveling junction box
- Long service life due to extremely high resistance to vibrations and shocks
- Use even in adverse environmental conditions due to the high degree of protection from IP66/IP67 and IP69K
- Reliable immunity for environments exposed to particularly high EMC interference



Its totally robust design permits interference-free speed feedback for large asynchronous motors. This even applies to severe vibrations.

Compact Reliability under Heavy Loads

These compact absolute rotary encoders are used for handling constant shocks and vibrations, high bearing loads, dirt, and temperature fluctuations. They are ideal where these conditions exist. The main area of application is in cranes, excavators, and lifting systems. Their strength is boundless reliability, even under the most adverse conditions.



Robust Design for Increased Service Life

These encoders combine compact dimensions with simple mounting. The rugged housing design can withstand high bearing forces. It is resistant to constant shocks and vibrations. The resolution of up to 1° offers the most precise positioning of movable tools on lifting systems or cranes. This even applies to offshore applications and other harsh environments.

Technical Information	
Design	Ø 36 mm, 42 mm
Shaft type	Solid shaft
Shaft dimension	Ø 10 mm
Flange type	Servo flange
Max. rotational speed	6,000 rpm
Degree of protection	IP66, IP67, and IP69K
Max. shaft load	Axial: 180 N, 270 N radial: 180 N, 270 N
Connection type	Connector plug
Connection output	Axial and radial
Electrical interface/order code	SSI AVS36H, AVM36H, AVS42H, AVM42H
	CANopen CVS36H, CVM36H, CVS42H, CVM42H
	J1939 JVS36H, JVM36H, JVS42H, JVM42H
	Analog UVS36H, UVM36H, IVS36H, IVM36H UVS42H, UVM42H, IVS42H, IVM42H
Max. bit count	Single turn: 4,096 (12 bit), multiturn: 8,192 (13 bit)

Highlights

- Sturdy design ensures long service life under extreme operating conditions
- Optimized for mobile equipment and also for offshore applications with stainless steel housing and IP69K degree of protection
- Compact design for confined spaces
- Noncontact technology for high reliability



These compact yet robust heavy-duty rotary encoders are ideal for mobile machinery.

Protection for the Most Extreme Conditions

This bearing box offers optimum protection against the effects of strong forces and is ideally suited for applications with an extremely high bearing load. It increases service life and ensures that functionality is preserved for a long time and plant availability remains reliable.



Large Bearing Clearances for Maximum Loads

This bearing box is suitable for rotary encoders with a recessed hollow shaft and torque rest. It is used in applications with particularly high shaft loads. It absorbs the forces to which the rotary encoder would normally be exposed. Providing a rugged bearing design with large bearing clearances also helps prevent damage to the rotary encoder. Its saltwater-resistant housing is ideal for offshore applications.

Technical Information	
Design	Ø 69 mm
Shaft type	Solid shaft
Shaft dimension	Ø 12 mm
Flange type for rotary encoder mounting	Hollow shaft flange with torque rest, 58 mm design
Flange type for application	Clamping flange
Max. rotational speed	6,000 rpm
Degree of protection	IP66, IP67, and IP69K
Max. shaft load	Axial: 200 N, radial: 250 N
Mechanical interface for rotary encoder mounting	Rotary encoder with Ø 12 mm × 20 mm recessed hollow shaft Rotary encoder with Ø 12 mm × 24 mm recessed hollow shaft Rotary encoder with Ø 10 mm × 20 mm recessed hollow shaft
Order code	BRB

Highlights

- Increased service life of the rotary encoder as a result of absorbing large shaft loads
- Extremely resistant to vibrations and shocks due to sturdy design
- High corrosion resistance allows use in offshore applications



Offshore Rotary Encoders: Weather-Resistant Encoders for Highly Corrosive Environments

Wind turbines or gantry systems out at sea are exposed to wind and weather conditions unlike those experienced by any other type of technical equipment. In this environment, rotational motion must be accurately captured and controlled. Special rotary encoders for offshore applications from Pepperl+Fuchs help align wind turbines, adjust rotor blades, and monitor rotations.

Totally Robust

Offshore rotary encoders are insensitive to shocks and vibrations, can handle constantly high humidity, and work reliably at temperatures between $-40\text{ }^{\circ}\text{C}$ and $60\text{ }^{\circ}\text{C}$. Special seals and housing coatings ensure that there are no spots where corrosion can attack and that the interior is permanently protected from the effects of the weather. Its extremely compact design is ideal for the often confined mounting conditions in offshore applications. Typical areas of application are drive and control systems in shipbuilding and marine equipment, lifting and lowering devices for docks, and renewable energy including onshore and offshore wind turbines.

Typical Areas of Application

- Offshore and shipbuilding
- Renewable energy
- Machine and plant engineering
- Mobile equipment
- Material handling

Reliable Operation in a Maritime Environment

This encoder is specifically designed for use in maritime environments and in extremely cold regions. Fields of application include wind turbines near the coast or at sea. Its seawater-proof coated housing and a specially designed shaft are ideal for harsh environments.



Robust Construction

This compact rotary encoder is ideal for space-saving integration. Its robust design guarantees a long service life. With a temperature range from -40°C to 60°C , this encoder can handle severe temperature fluctuations. It provides high availability for wind turbines, gantry cranes, or spreaders that are often difficult to access and therefore involve complex maintenance work.

Technical Information	
Design	Ø 58 mm
Shaft type	Recessed hollow shaft
Shaft dimension	Ø 12 mm
Flange type	Hollow shaft flange with saltwater-resistant torque rest
Max. rotational speed	100 rpm
Degree of protection	IP65, IP66, and IP68
Connection type	Connector plug
Connection output	Radial
Electrical interface	Push-pull
Resolution	Up to 50,000 pulses
Order code	RSI580

Highlights

- Resistance to high humidity and corrosion for use in offshore applications
- Long service life through sturdy sensor design with special housing coating
- Large range of applications due to extended temperature range of -40°C to 60°C



The offshore encoder enables reliable, accurate feedback of generator speed.



Insensitive and Resistant to Interference

Encoders used in maritime applications must not only be saltwater-resistant; they must also be resistant to shocks and vibrations, and immune to electrical currents that can be caused by induced voltages in the shaft of the drive motor. This durability guarantees a long service life and reduces maintenance. No mechanical slip between the rotary encoder and shaft ensures interference-free operation.

Technical Information

Design	Ø 90 mm
Shaft type	Hollow shaft; shaft with flat areas on both sides
Shaft dimension	Ø 16 mm
Flange type	Hollow shaft flange with saltwater-resistant and isolated torque rest (support plate and articulated arm)
Max. rotational speed	3,000 rpm
Degree of protection	IP65
Connection type	Connector plug
Connection output	Radial
Electrical interface	Push-pull
Resolution	Up to 5,000 pulses
Order code	RHI900

Highlights

- Total immunity for environments exposed to high EMC interference
- Resistance to high humidity and corrosion for use in offshore applications
- Long service life through sturdy sensor construction with a special shaft design
- Large range of applications due to extended temperature range of –40 °C to 60 °C



Rotary Encoders for Hazardous Areas: Safe Processes for Explosive Environments

Hazardous areas place very specific demands on encoders. These encoders are used in oil and gas production, chemical processes, or industrial plants where flammable gas mixtures can occur. As a world leader in the field of explosion protection, Pepperl+Fuchs stands for the highest standards and guarantees absolutely secure processes.

For Each Application a Reliable Solution

The variety of applications in hazardous areas is almost unlimited. Different requirements apply in terms of what type of protection to consider for industry or country-specific guidelines. To meet these requirements, Pepperl+Fuchs provides appropriate types of protection including flameproof (Ex d) and intrinsic safety (Ex i). Various encoder options are available for use in Zones 1, 2, 21, and 22. Certificates such as IECEx, Ex NEPSI, or KOSHA complete the program.

Typical Areas of Application

- Oil and gas
- Chemical industry
- Mobile equipment
- Material handling
- Process equipment
- Offshore and shipbuilding
- Mining

For more information, see the brochure Solutions for Process Automation or visit www.pepperl-fuchs.com

Safe Operation in Hazardous Environments

This rotary encoder is specifically designed for use in hazardous areas in Zone 1. Its technical design is consistent with the Ex i type of protection. Because this encoder is intrinsically safe, it works with electrical values that are too low for the ignition of an explosive atmosphere.



Safe Process Flows

This rotary encoder is used in the chemical industry, e.g., in painting and drying plants, wastewater treatment plants, and power plants. It is ideal for areas in which an explosive atmosphere can form as a mixture of air and flammable gases, vapors, or mists. It has a resolution of 25 pulses at a rotational speed of up to 3,000 revolutions per minute. A robust housing design ensures a long service life. The encoder is fitted with an intrinsically safe NAMUR interface according to DIN EN 60947-5-6.

Technical Information

Design	Ø 78 mm
Shaft type	Solid shaft
Shaft dimension	Ø 10 mm
Flange type	Clamping flange
Max. rotational speed	3,000 rpm
Degree of protection	IP65
Connection type	Cable
Connection output	Axial
Electrical interface	NAMUR interface according to DIN EN 60947-5-6
Max. shaft load	Axial: 50 N, radial: 100 N
Resolution	Up to 25 pulses
Certification	Ex II 2G c Ex ia IIC T6 Gb
Order code	RV184

Highlights

- Safe for use in a hazardous, explosive atmosphere of gases (Zone 1)
- Robust housing design for increased service life
- NAMUR interface according to DIN EN 60947-5-6

Certified for Worldwide Use

Hazardous area encoders offer a rugged bearing construction to accommodate high shaft loads. Thus, they operate extremely reliably even under demanding conditions. The compact design allows easy installation in confined spaces.



Suitable for Any Climate

This encoder comes with ATEX, IECEx, Ex NEPSI, and KOSHA certification. It offers a high degree of protection and features seawater-resistant housing, which makes it suitable for use in offshore applications. The encoder has a high rotational speed of 6,000 revolutions/min with an extended temperature range from $-40\text{ }^{\circ}\text{C}$ to $70\text{ }^{\circ}\text{C}$, which allows reliable use in extreme climatic conditions. A compact design ensures efficient use of installation space.

The encoder has Group I certification for the mining industry and Group II certification for the surface industry.

Technical Information	
Design	Ø 69 mm
Shaft type	Solid shaft
Shaft dimension	Ø 10 mm–Ø 12 mm
Flange type	Clamping, servo, and Euro flange
Max. rotational speed	6,000 rpm
Degree of protection	IP66 and IP67
Connection type	Cable
Connection output	Axial and radial
Electrical interface	Push-pull and RS-422
Max. shaft load	Axial: 110 N, radial: 150 N
Resolution	Up to 5,000 pulses
Certification	Ex II 2G Ex d IIC T6–T4 Gb Ex II 2D Ex t IIIC T80°C Db IP6X Ex NEPSI KOSHA
Order code	RV170E

Highlights

- Certification for worldwide use
- Robust bearing design ensures a long service life
- Compact design, ideal for confined spaces
- Suitable for use in challenging environments with a high degree of protection and a seawater-resistant housing
- Large range of applications due to extended temperature range of $-40\text{ }^{\circ}\text{C}$ to $70\text{ }^{\circ}\text{C}$ and high rotational speeds
- Wide range of variants for easy adaptation to any application



Flexible Mounting and Wiring

This encoder is suitable for speeds of up to 3,000 rpm and is designed for a temperature range of -40 °C to 70 °C. It conforms to the Ex d type of protection and meets the international ATEX, IECEx, and Ex NEPSI requirements for gases according to Zones 1 and 2, and for dust according to Zones 21 and 22. It has a modular design with a removable connection cover that simplifies mounting and maintenance. For fieldbus versions, the bus coding can be freely programmed directly on site. The 78E encoder has Group I certification for the mining industry and Group II certification for the surface industry.

Technical Information	
Design	Ø 78 mm
Shaft type	Solid shaft
Shaft dimension	Ø 10 mm–Ø 12 mm
Flange type	Clamping flange and servo flange
Max. rotational speed	3,000 rpm
Degree of protection	IP66
Connection type	Cable and cable gland with stopping plug
Connection output	Radial
Electrical interface/order code	SSI AVS78E, AVM78E
	CANopen CVS78E, CVM78E
	PROFIBUS PVS78E, PVM78E
	DeviceNet DVS78E, DVM78E
Max. shaft load	Axial: 60 N, radial: 80 N
Max. bit count	Single turn: 65,536 (16 bit), multiturn: 16,384 (14 bit)
Certification	Ex II 2G Ex db IIC T5 Gb Ex II 2D Ex tb IIIC T100°C Db IP6X Ex I M2 Ex db I/IIC T5 Ex NEPSI

Highlights

- Removable connection cover: flexible mounting and wiring on site
- Simple maintenance: separation of the cable and rotary encoder means there is no need to replace the entire device
- ATEX, IECEx, and Ex NEPSI certification for worldwide use in Zones 1 and 21
- Wide range of variants for easy adaptation to any application
- Specially designed for offshore applications
- Robust design for use in extreme conditions

Reliable Operation for Dusts and Vapors

These rotary encoders with nA type of protection meet the requirements for explosion protection in Zones 2 and 22. Dust-tight housing effectively prevents explosions caused by sparks, heat, or dust accumulation on the housing. A compact design and a removable bus cover offer increased flexibility even in hazardous areas.



Compact and Flexible

This encoder delivers up to 5,000 pulses per revolution through either a push-pull output or an RS-422 interface. It is no larger than the corresponding standard design and is ideal for integration into plants with limited installation space. Due to its 58 mm standard housing, installing this encoder on a machine for use in hazardous areas is also ideal.

Technical Information	
Design	Ø 58 mm
Shaft type	Solid and recessed hollow shaft
Shaft dimension	Solid shaft: Ø 6 mm–Ø 10 mm Recessed hollow shaft: Ø 10 mm–Ø 12 mm
Flange type	Clamping, servo, and solid shaft flange with torque rest
Max. rotational speed	6,000 rpm
Degree of protection	IP54 and IP64
Connection type	Cable
Connection output	Axial and radial
Electrical interface	Push-pull and RS-422 (extended voltage range)
Max. shaft load	Axial: 40 N, radial: 60 N
Resolution	Up to 5,000 pulses
Certification	Ex II 3G Ex nA IIB T4 Gc Ex II 3D Ex tc IIIC T105°C Dc IPXX
Order code	RVI58X, RSI58X

Highlights

- Use in hazardous, explosive atmospheres of gases or dusts
- Compact design for confined spaces
- High signal accuracy with up to 5,000 pulses
- Flexible application and mounting options



Simplified Commissioning and Maintenance

This rotary encoder is available with a PROFIBUS interface that allows easy mounting on the shaft. It has a resolution of up to 16 bit for single turn (ST) and has up to 14 bit for the number of turns (MT). With its compact housing design, the rotary encoder can be flexibly mounted even where space is limited. A removable bus cover makes installation easier and reduces maintenance.

Technical Information	
Design	Ø 58 mm
Shaft type	Solid and recessed hollow shaft
Shaft dimension	Solid: Ø 6 mm–Ø 10 mm Recessed hollow: Ø 10 mm–Ø 15 mm
Flange type	Clamping, servo, and solid shaft flange with torque rest
Max. rotational speed	6,000 rpm
Degree of protection	IP64 and IP66
Connection type	Connector plugs and cables
Connection output	Radial
Electrical interface/order code	PROFIBUS PVS58X, PVM58X, PSS58X, PSM58X
Max. shaft load	Axial: 40 N, radial: 110 N
Max. bit count	Single turn: 65,536 (16 bit), multiturn: 16,384 (14 bit)
Certification	Ex II 3G Ex nA IIB T4 Gc Ex II 3D Ex tc IIIC T120°C Dc IP6X

Highlights

- Use in hazardous, explosive atmospheres of gases or dusts
- Simplified system integration with removable bus cover
- Compact design for confined spaces
- High resolution with up to 16 bit (ST), 14 bit (MT)
- Flexible mounting with a wide range of application and mounting options



Safety Rotary Encoders: Safe Function Flows for Man and Machine

The risk of injury or death for the people working on automatically controlled machines and processes can never be completely prevented. The Machinery Directive demands proof of safety based on clearly defined criteria. Pepperl+Fuchs rotary encoders have the necessary certification and can be seamlessly integrated into all standard safety systems.

Safety in Accordance with the Machinery Directive

Automatically controlled machines must be equipped with a security system that meets a clearly defined security level. The Machinery Directive 2006/42/EC requires that each machine and plant is fitted with appropriate safety measures. The encoder must meet a certain level of safety based on the performance level (PL) or safety integrated level (SIL).

Safety with a Certificate of Compliance

Certified safety rotary encoders from Pepperl+Fuchs make a key contribution to the safety of a machine or plant. They are based on innovative technical concepts and complemented by the use of existing communication paths. The certificate of compliance supports the proof required for safety categories up to SIL 3 according to IEC 61508.

Typical Applications

- Plants with areas of application that come under the requirements of Machinery Directive 2006/42/EC
- Machine and plant engineering
- Mobile equipment
- Renewable energy
- Material handling
- Print and paper industry
- Packaging industry
- Doors, gates, and elevators

Reliable Machine Monitoring

Certified according to SIL 3 and PL e, this encoder is the perfect encoder for all machines requiring reliable functionality in accordance with Machinery Directive 2006/42/EC. Fields of application include machine tools, monorail conveyors, and packaging machines. It provides feedback so that control systems monitoring machinery movements can, in the event of a malfunction, limit speeds and rotational speeds to safe values and down to a standstill where necessary.



Protection against Hazards in the Process Flow

A sine-cosine rotary encoder interface delivers 1,024 or 2,048 signal periods. It detects and safely communicates malfunctions, allowing machines to transition to a safe state in order to reliably prevent risks to the operating personnel. Standardized interfaces allow simple integration into the existing system environment. Extended temperature range of up to 115 °C is possible.

Technical Information	
Design	Ø 58 mm
Shaft type	Solid shaft
Shaft dimension	Ø 6 mm
Flange type	Servo flange
Max. rotational speed	12,000 rpm
Degree of protection	IP65
Connection type	Cable
Connection output	Radial
Electrical interface	Sine-cosine
Max. shaft load	Axial: 40 N, radial: 60 N
Resolution	Up to 2,048 pulse
Certification	SIL 3 in accordance with IEC 61508 and IEC 62061, performance level e according to ISO 13849 TÜV SÜD
Order code	RVS58S

Highlights

- Ensuring safety to protect man, machinery, and the environment
- Continuous plant operation during maintenance or conversions
- Reduction of safety-related downtime
- Provides feedback to a safety system, so safe speed, safe direction, and safe standstill can be monitored
- Elimination of mechanical safety devices
- Minimization of safety areas



The safety rotary encoder protects against hazards in the process flow. It provides feedback to a safety system so safe speed, safe direction, and safe standstill can be monitored.

Fully Integrated Safety Functions

The safety absolute rotary encoder is certified to SIL 3 and PL e. It is used for robotics, hoisting gear, lifters, gate locks, and a host of other applications that must be designed in accordance with Machinery Directive 2006/42/EC. This encoder can be seamlessly integrated into existing system environments. It reduces downtime for maintenance and conversions.



Added Safety and Machine Availability

In accordance with the CANopen safety protocol, this absolute encoder ensures the security of plant and machinery and increases availability. To communicate with other CANopen control components the encoder features a CANopen interface. The redundant and diverse concept allows secure transfer of data and reliable processes.

The encoder performs complex diagnostics as well as the verification of measurements and facilitates the representation of safety-related requirements. Even during maintenance or plant and machinery upgrading, continuous operation is guaranteed and security-related downtime is reduced.

Technical Information		
Design	Ø 58 mm	
Shaft type	Solid shaft	
Shaft dimension	Ø 6 mm and Ø 10 mm	
Flange type	Clamping flange and servo flange	
Max. rotational speed	12,000 rpm	
Degree of protection	IP66	
Connection type	Connector plugs and cables	
Connection output	Radial	
Electrical interface/order code	CANopen/ CANopen Safety	CVS58S CVM58S
Max. shaft load	Axial: 40 N, radial: 110 N	
Max. bit count	Single turn: 65,536 (16 bit), multiturn: 16,384 (14 bit)	
Certification	SIL 3 in accordance with IEC 61508 and IEC 62061, performance level e according to ISO 13849	

Highlights

- Ensuring safety to protect man, machinery, and the environment
- Continuous plant operation during maintenance or conversions
- Reduction of safety-related downtime
- Simultaneous operation of CANopen and CANopen safety protocol

Safe Speed and Position Monitoring

The Safe Speed and Position Monitor provides safety functions for monitoring process conditions. The monitor is ideal for retrofitting safety functionality to existing plants. It meets all safety requirements up to SIL 3 /PL e when combined with one safety or two standard rotary encoders.



Slim, Complete Solution

The position and speed monitor facilitates plant integration without modification of existing components. In combination with only one safety or two standard rotary encoders, a security level up to SIL 3/PL e can be realized. An incremental rotary encoder with sine-cosine or TTL interface, as well as absolute rotary encoders with an SSI interface can be used. This enables a safe monitoring of standstill, speed, direction of rotation, brake ramp, and position for up to two axes. An additional safety control unit is not required, which considerably reduces the installation effort.

For series applications, an integrated chip card facilitates the commissioning of additional modules. The stored data can be easily transferred to other units without reparameterization.

Technical Information	
Design	45 mm width for DIN rail mounting
Interface	Chip card slot and Micro USB
Input	2 inputs for incremental rotary encoders via Mini I/O connector and 4 additional safety inputs for external safety sensors
Output	Output circuits 1 and 2
Degree of protection	Module: IP20
Connection type	Removable terminals
Order code	Module: VBA-2E2A-KE4-ENC/SSI-S Monitor: VAS/M-2A8L-KE4-6SE-EV
Suitable encoder	RVS58S, RVI58, RSI58, ENA58IL, ENA36IL, AVM58, ASM58, AHM58

Highlights

- Slim complete solution for all safety categories with only one safety rotary encoder or two standard encoders per axis
- Monitoring of standstill, speed, direction of rotation, brake ramp, and position for two axes, as well as additional safe inputs/outputs
- Certified functional safety up to SIL 3 /PL e
- Extremely simple component replacement without reconfiguration via chip card
- Suitable for incremental rotary encoders with sine-cosine or TTL interface and absolute rotary encoders with SSI interface



Cable Pulls and Cable Pull Rotary Encoders: Linear Distance Measuring for a Wide Range of Applications

Pepperl+Fuchs' portfolio of modular cable pull encoders is designed using a modular product architecture. Different components are combined to create a cable pull rotary encoder in a range of housing materials and encoder types. They are easily tailored to meet the exact needs of your application requirements. From compact models that are designed for use in simple applications to rugged, heavy-duty versions for extremely harsh environments, this product portfolio provides accurate measurement, durability, a long service life, and is flexibly integrated into any environment.

Linear Position Measurement with a Rotary Encoder

Cable pulls enable rotary encoders to measure linear motion using a simple rotating drum principle. Inside the cable pull, a steel cable is wrapped around a spring-loaded drum that rotates the connected encoder shaft when the cable is extended or retracted from the cable pull. Each revolution of the encoder shaft then represents linear movement of the cable equal to the circumference of the measuring drum. In this way, linear movement is translated into a rotary motion allowing the encoder output signal to represent linear distance of the connected mechanical device.

Modular Design for Diverse Applications

A modular design and an extensive selection of attachment accessories open up a wide range of application solutions. Models are available in compact housings for simple applications as well as heavy-duty versions for extremely harsh environments. Cable pull and encoder combinations are available in all standard interfaces to provide simple wiring and communication connections, and with measuring lengths up to 60 meters, we have a device for virtually every application.

Robust in the Harshest of Applications

Cable pull rotary encoders are a practical solution for many industrial sectors. When used in automated guided vehicles, for example, they can be integrated into a lifting unit to measure position and speed. On mobile cranes, they monitor the linear movement of booms, in real time, sending precise information about the boom's current position to the crane control unit.

Pepperl+Fuchs offers heavy-duty versions specifically designed for marine or outdoor environments typically found in shipbuilding and offshore applications. These heavy-duty versions can offer reliable solutions for the extremely harsh environments in steel mills, on mobile equipment, conveyor systems, cranes, and wind power plants.

Typical Applications

- Material handling
- Automotive industry
- Doors, gates, elevators
- Mobile equipment
- Steel industry
- Offshore and shipbuilding
- Medical engineering

Remarkably Compact, Impressively Accurate

When space is limited but precision is required, the cable pulls in this product family are the ideal choice. Featuring a remarkably compact and flexible housing design, these cable pulls can be easily integrated into almost any machine structure



Space-Saving and Flexible

This product family comes in a lightweight, compact housing that easily fits in the tightest spaces. The slim housing is designed to allow the cable pull to be mounted on one of three sides, and it easily interfaces with control systems, making it easy to integrate into existing systems. Because no coupling is required for this cable pull, it offers precise information feedback for consistently reliable and accurate positioning. Typical applications for the ECN10TL include precisely adjusting the height of the lift platform of automated guided vehicles or measuring the fork position on forklift trucks.

Technical Information

Measuring range	3,000 ... 10,000 mm
Construction type	80 mm, 130 mm, 190 mm
Repeat accuracy	0.005 %
Linearity	± 0.01 %
Rope diameter	0.55 mm
Degree of protection	IP50
Material	Housing: Plastic Rope: Stainless steel 1.4401/316
Order code	ECN10TL

Highlights

- Very lightweight, compact design makes it easy to handle and allows installation in tight spaces
- Multiple mounting options reduce installation costs and increase flexibility
- Direct coupling ensures accurate information feedback and reliable process control

Robust Solution for Industrial Environments

Designed for harsh industrial environments, this family of cable pulls comes in a durable aluminum housing and includes a measuring cable that is rust- and acid-resistant. It has a compact footprint for flexible mounting in tight spaces and can be used in an extensive range of applications.



Versatile, Compact, and Tough

The cable pulls in this product family are extremely shock-resistant and are offered with an optional anodized aluminum coating for increased protection against wear and corrosion. The steel-tipped bellows provide increased protection against dust, moisture, and ice formation on the measurement cable with attachments to reduce maintenance and increase service life. The ECN20IL cable pull encoders are used effectively on automated stacker cranes and storage robots and can be used to measure the working heights of lifting platforms and scissor lift tables.

Technical Information

Measuring range	1,250 ... 5,000 mm
Construction type	55 mm, 80 mm, 130 mm
Repeat accuracy	0.1 %
Linearity	± 0.1 %
Rope diameter	0.55 mm
Degree of protection	IP64
Material	Housing: Aluminum or anodized aluminum coating Rope: Stainless steel 1.4401/316
Order code	ECN20IL

Highlights

- Robust solution for reliable use in harsh industrial environments
- Compact design for flexible installation in tight spaces
- Optional anodized aluminum coating for use in adverse environments
- Cable outlet options protect the cable pull and reduce maintenance while increasing durability
- Increased flexibility for cable entry/exit angles

Flexible for Demanding Applications

The cable pulls in this product family are designed for tough environments and high cycle counts. They provide reliable measurement results over long distances and have a comprehensive range of mounting options and accessories that can be combined for increased flexibility and service life.



A Focus on Process Reliability

With a drum that moves in an axial direction via a threaded spindle, this cable pull provides dependable linearity and precision over the longest distances. An optional anodized coating provides protection from aggressive contaminants, fuel and petroleum products, chemicals, lubricants, and the rigors of a marine environment: high moisture and humidity, and salt spray. Measurement lengths up to 60 m provide precise measurement for the largest machines.

These features make the ECN30PL series the number-one choice for offshore, shipbuilding, and mobile equipment applications.

Technical Information	
Measuring range	1,000 ... 60,000 mm
Housing design	80 mm, 130 mm, 190 mm
Construction type	0.1 %
Linearity	± 0.1 %
Rope diameter	1.35 mm
Degree of protection	IP64
Material	Housing: Aluminum or anodized aluminum coating Rope: Stainless steel 1.4401/316
Order code	ECN30PL

Highlights

- Robust solution for reliable use in harsh industrial environments
- Axial drum movement via threaded spindle ensures consistent linearity
- Optional anodized aluminum coating for use in adverse environments
- Increased flexibility for cable entry/exit angles
- Various cable pull attachments and combinations provide increased flexibility and durability

Extremely Robust in Challenging Environments

This heavy-duty cable pull has a rugged, anodized aluminum housing for use in exceptionally harsh conditions. It incorporates a grooved cable drum and guiding wheel for increased reliability, accuracy, and service life. An open cable system is used to easily remove debris and ice, and enable trouble-free use in dusty, dirty, humid, and salty environments.



Consistent Reliability

Unimpaired by salt spray, extreme weather conditions, or large temperature fluctuations, this product family stands for durability without compromise. A grooved cable drum specifically designed to match the structure and length of the measuring cable eliminates snagging and ensures that the cable spools smoothly. The stainless steel measuring cable, 2 mm in diameter, has a protective coating to ensure a durable performance.

The rugged ECN40HD family is the one to ensure that rolling machines and feed machines, together with trolley, gantry, and marine cranes can be operated reliably in the harshest of environments.

Technical Information

Measuring range	5,000 ... 20,000 mm
Drum perimeter	500 mm
Construction type	190 mm
Repeat accuracy	0.1 %
Linearity	± 0.1 %
Rope diameter	2 mm
Degree of protection	IP65
Material	Housing: Aluminum or anodized aluminum coating Rope: Stainless steel 1.4401/316, plastic sheathing
Order code	ECN40HD

Highlights

- Especially robust solution for extremely harsh environmental conditions
- The open cable system allows easy cleaning and facilitates handling
- Grooved cable drum and guiding wheel for increased accuracy and long service life
- Ball joint as cable attachment increases the flexibility and durability of the measuring cable



PEPPERL+FUSO



PEPPERL+FUSO

The Perfect Supplement

Perfectly coordinated connection and mounting technology ensures optimum integration of a rotary encoder. Pepperl+Fuchs' comprehensive range of accessories provides all necessary components for a ready-to-install solution to your specific requirements.

Mounting Set for Hollow Shaft and Recessed Hollow Shaft Rotary Encoders

This set is used to connect the rotary encoder and motor shaft stator couplings, torque spring plates, and torque rests.

Mounting Set for Rotary Encoders with a Solid Shaft

This set contains shaft couplings, mounting and eccentric clamping elements, mounting aids and domes, and adapter flanges to ensure that the rotary encoder stays firmly in place.

Electrical Connection

For optimum connection of the rotary encoder, appropriate single-ended cordsets, connectors, and connecting cables are available.

Measuring Wheels

These measuring wheels are equipped for any surface in various sizes, coatings, and bearing surface structures.

Evaluation

Various counters, for example, display, preselection, or cumulative counters are available for precise signal evaluation.

Cable Pull Accessories

The comprehensive range of cable attachments, suspensions, and pulleys allows constant, reliable measurement results and ensures an increased service life even under difficult ambient conditions.



Automation is our world. A perfect application solution is our goal.

A willingness to take entrepreneurial risks, a pioneering spirit, and a firm belief in their own inventive powers – these were the assets that Walter Pepperl and Ludwig Fuchs started out with when they opened their Mannheim radio repair shop in 1945. Their invention of the proximity switch a few years later proved their strength. It was also the starting point in a successful history defined by close customer relationships as well as innovative automation technologies and procedures.

Then as now, our focus is directed squarely on the individual requirements of each customer. Whether as a pioneer in electrical explosion protection, or as a leading innovator of highly efficient

sensors – the close communication with our customers is what allowed us to become the leader in automation technology. Our main objective is combining state-of-the-art technologies and comprehensive services to optimize our customers' processes and applications.

For more information, please visit our website:

www.pepperl-fuchs.com

Your automation, our passion.

Explosion Protection

- Intrinsically Safe Barriers
- Signal Conditioners
- Fieldbus Infrastructure
- Remote I/O Systems
- HART Interface Solutions
- Surge Protection
- Wireless Solutions
- Level Measurement
- Purge and Pressurization Systems
- Industrial Monitors and HMI Solutions
- Electrical Explosion Protection Equipment
- Solutions for Explosion Protection

Industrial Sensors

- Proximity Sensors
- Photoelectric Sensors
- Industrial Vision
- Ultrasonic Sensors
- Rotary Encoders
- Positioning Systems
- Inclination and Acceleration Sensors
- Fieldbus Modules
- AS-Interface
- Identification Systems
- Displays and Signal Processing
- Connectivity